

FRONT ELEVATION

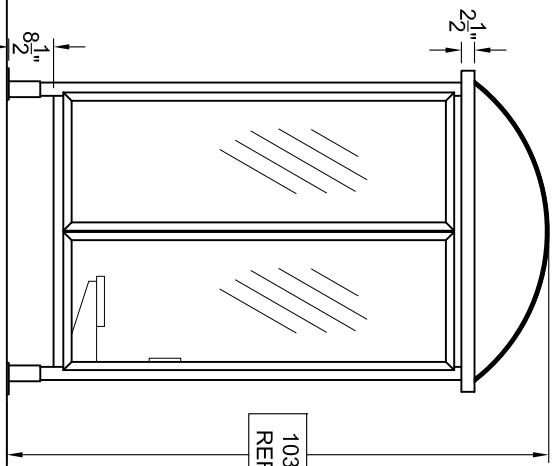

SIDE ELEVATION

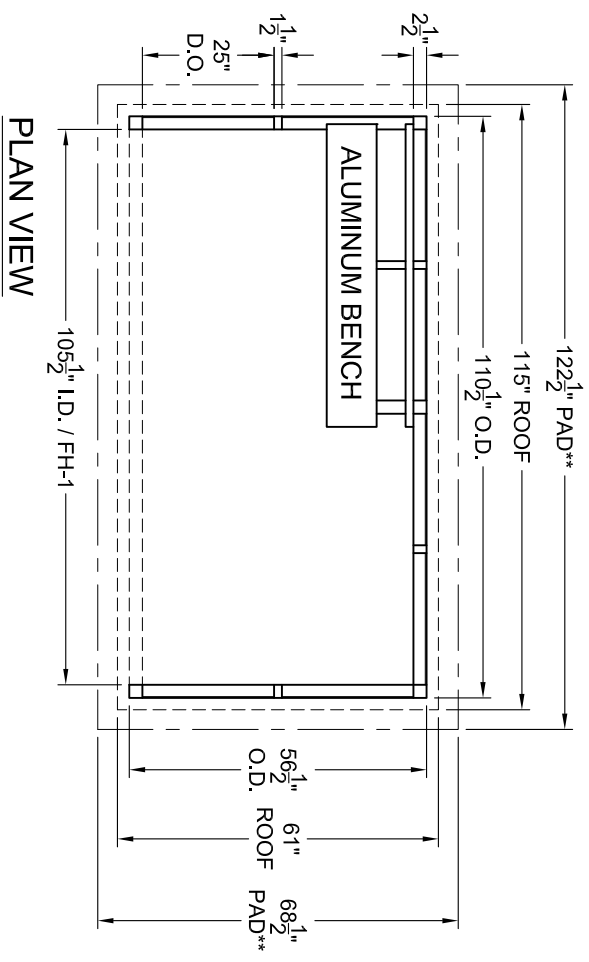

PLAN VIEW

84" CLEAR OPENING

103" REF.

- SHELTER NOTES:**
- FINISH IS DARK BRONZE ANODIZED
  - ROOF IS 6MM BRONZE PCSS BARREL VAULT
  - WALL GLAZING IS 1/4" CLEAR TEMPERED GLASS
  - ADA LENGTH ALUMINUM BENCH AND BACKREST
- \*\*PAD BY OTHERS, DIMENSIONS ARE RECOMMENDATION ONLY\*\*

Duo-Gard Industries, Inc.  
Tel (734) 207-9700 Fax (734) 207-7995  
www.duo-gard.com

THIS DRAWING IS PROPRIETARY AND FOR THE SOLE USE OF OUR CUSTOMER AND MAY NOT BE COPIED OR REPRODUCED WITHOUT PRIOR WRITTEN CONSENT FROM DUO-GARD INDUSTRIES, INC. LEAD TIME BEGINS UPON RECEIPT OF SIGNED SHOP DRAWINGS

APPROVAL SIGNATURE \_\_\_\_\_ DATE \_\_\_\_\_

PROJECT NAME		READY SHIP SHELTER	
DESCRIPTION		5' X 10' TRANSIT STYLE SHELTER - PLAN AND ELEVATIONS	
PRJT ENG	PRJT MGR	DMG DATE	REV1
XXX	XXX	XXX	REV2
SCALE	PAGE	OF	DRAWING #
NTS	X	X	XXX